



BLOCKS

BLOCKS



www.vanguardsteelvancouver.com

www.vanguardsteel.com

VANGUARD STEEL LTD.

BLOCKS



BLOCKS

TABLE OF CONTENTS

	Page
General Information	1
SK-05 Korean Type	2
V-1800 Snatch Block with Hook	3
V-1900 Snatch Block with Swivel Shackle	4
V-4000 Snatch Block Tail Board	5
Gin Block	6
Roller Shackle	7
FX Yarding Block	8
Yarding Block	9



MAINTENANCE:

To ensure peak efficiency and sea and extended service life, it is necessary that blocks be inspected and maintained at frequent intervals:

Inspection procedures for any sign of wear or damage, such as:

- Worn or damaged shifts bushings slide plates and pins hooks or shackles: replace any part showing signs of wear or damage!
- Hook latch for proper fit and operation. Replace deformed latches!

These particular blocks feature bronze bushings, which are not self lubricating. They are designed for infrequent or intermediate use with low line speed.

Observe the following lubrication schedule.

- Moderate use : Every 6-8 hours
- Intermittent operation: Once weekly

LOADS:

Throughout this catalog, the term working load limit (abbreviated: WLL) is being used. It refers to the maximum load or force which a product is designed to support under normal operating and environmental conditions and the product being in and as new condition.

IMPORTANT:

The total load on a snatch block, and therefore also on any fittings which is attached to the block, is usually considerably greater than the actual load lifted or pulled. The deciding factor in determining the total load on a single line block is the angle between the lead line and the load line:

Total load on Block = Actual Load Lifted x Multiplication Factor (single line systems only):

Lead/Load Line Angle	Factor	Lead/ Load Line An- gle	Factor	Lead/ Load Line An- gle	Factor
0°	2.00	60°	1.73	130°	0.84
10°	1.99	70°	1.64	135°	0.76
20°	1.97	80°	1.53	140°	0.68
30°	1.93	90°	1.41	150°	0.52
40°	1.87	100°	1.29	160°	0.35
45°	1.84	110°	1.15	170°	0.17
50°	1.81	120°	1.00	180°	0.00

WARNING

Never Exceed working load limits !

Always refer to load calculations based on line angle!



SK 05 Korean Type Block

Used for lashing equipment on lumber vessels and log carriers



SK 05 Block									
Sheave				Rope		WLL	Weight		Product
Dia. (in.)				Size (in.)		Tons	lbs/pc		Code
6				3/4-15/16"		5	35.3		29356060

Ultimate load

2 x the Working Load Limit (WLL)

WARNING

Never Exceed working load limits !

V-1800 Snatch Blocks with Hook

Bronze Bushed-Supplied with latch kit
 Designed for intermittent use with low line speed.
 Ultimate load is 4 x Working Load Limit (WLL)

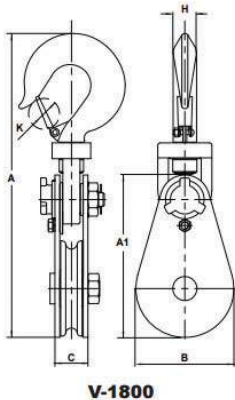

V-1800									Weight	Product
WLL Tons	Sheave Dia.	Rope Dia.	A	A1	B	C	H	K	lbs/pc	Code
2	3"	3/8"	9.65	4.88	2.99	1.50	0.79	0.91	3	29362030
4	4-1/2"	1/2"	14.09	7.46	4.25	1.99	1.18	1.50	12	29362045
8	6"	3/4"	17.91	9.65	5.98	2.30	1.42	1.81	27	29362060
8	8"	3/4"	19.88	11.78	7.99	2.30	1.42	1.81	35	29362080
8	10"	3/4"	21.89	13.90	10.00	2.30	1.42	1.81	50	29362100
15	8"	1-1/8"	24.72	13.29	7.99	2.72	1.69	2.09	58	29362081
20	8"	1-1/8"	28.15	14.80	7.99	3.35	2.28	2.60	103	29362082

Total Load on block= Actual Load Lifted x Multiplication Factor (single line systems only)

Lead/Load Line Angle	Factor	Lead/Load Line Angle	Factor	Lead/Load Line Angle	Factor
0°	2.00	60°	1.73	130°	0.84
10°	1.99	70°	1.64	135°	0.76
20°	1.97	80°	1.53	140°	0.68
30°	1.93	90°	1.41	150°	0.52
40°	1.87	100°	1.29	160°	0.35
45°	1.84	110°	1.15	170°	0.17
50°	1.81	120°	1.00	180°	0.00

WARNING Never Exceed working load limits !
 Always refer to load calculations based on line angle!

V-1900 Snatch Blocks with Swivel Shackle

Bronze Bushed-Supplied with latch kit
 Designed for intermittent use with low line speed.
 Ultimate load is 4 x Working Load Limit (WLL)



V-1900										Weight lbs/pc	Product Code
WLL Tons	Sheave Dia.	Rope Dia.	A	A1	B	C	H	K	L		
2	3"	3/8"	9.65	4.88	2.99	1.50	0.79	1.28	0.50	3	29353030
4	4-1/2"	1/2"	13.94	7.46	4.25	1.99	1.22	1.91	0.75	13	29353045
8	6"	3/4"	18.31	9.65	5.98	2.30	1.69	2.68	1.00	29	29353060
8	8"	3/4"	20.28	11.75	7.99	2.30	1.69	2.68	1.00	36	29353080
8	10"	3/4"	22.24	13.90	10.00	2.30	1.69	2.68	1.00	53	29353100
8	14"	5/8"	29.09	20.83	14.25	2.30	1.69	2.68	1.00	81	29353140
15	8"	1-1/8"	22.88	13.29	7.99	2.72	2.09	3.46	1.44	65	29353081
15	10"	7/8-1"	27.52	15.87	10.08	2.72	2.09	3.46	1.44	82	29353101
20	8"	1-1/8"	29.06	14.80	7.99	2.36	2.36	3.80	1.54	117	29353082

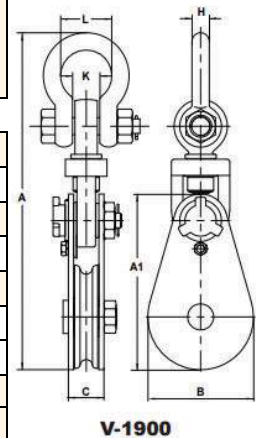

Total Load on block= Actual Load Lifted x Multiplication Factor (single line systems only)

Lead/Load Line Angle	Factor	Lead/Load Line Angle	Factor	Lead/Load Line Angle	Factor
0°	2.00	60°	1.73	130°	0.84
10°	1.99	70°	1.64	135°	0.76
20°	1.97	80°	1.53	140°	0.68
30°	1.93	90°	1.41	150°	0.52
40°	1.87	100°	1.29	160°	0.35
45°	1.84	110°	1.15	170°	0.17
50°	1.81	120°	1.00	180°	0.00

WARNING Never Exceed working load limits !
 Always refer to load calculations based on line angle!



V-4000 Tail Boards

Designed for intermittent use with low line speed.
 Ultimate load is 4 x Working Load Limit (WLL)

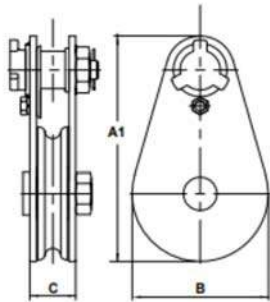

V-4000

V-4000						Weight lbs/pc	Product Code
WLL Tons	Sheave Dia.	Rope Dia.	A1	B	C		
2	3"	3/8"	4.88	2.99	1.50	3	29351030
4	4-1/2"	1/2"	7.46	4.25	1.99	8	29351045
8	6"	3/4"	9.65	5.98	2.30	15	29351060
8	8"	3/4"	11.75	7.99	2.30	25	29351080
15	8"	1-1/8"	13.29	7.99	2.72	35	29351081
20	8"	1-1/8"	14.80	7.99	3.35	70	29351083

Total Load on block= Actual Load Lifted x Multiplication Factor (single line systems only)

Lead/Load Line Angle	Factor	Lead/Load Line Angle	Factor	Lead/Load Line Angle	Factor
0°	2.00	60°	1.73	130°	0.84
10°	1.99	70°	1.64	135°	0.76
20°	1.97	80°	1.53	140°	0.68
30°	1.93	90°	1.41	150°	0.52
40°	1.87	100°	1.29	160°	0.35
45°	1.84	110°	1.15	170°	0.17
50°	1.81	120°	1.00	180°	0.00

WARNING

Never Exceed working load limits !

Always refer to load calculations based on line angle!

Gin Block

Gin Block Rope Pulley used with manila rope or synthetic 3 strand rope used by Roofers, Painters and Contractors for light hoisting and lifting.

Supplied with Drop Forged Swivel Hook and Latch.



Gin Blocks		Sheave Size								Rope Size (in.)	WLL (tons)	Weight (lbs/pc)	Product Code
Sheave Dia. (in.)	Outside Diameter	Rim Thickness	A	B	C	D	E	F	R				
12"	12"	1.38"	14.95	11.97	17.80	0.91	0.78	2.09	0.53	1	1	13	29354012

Ultimate load 3 x the Working Load Limit (WLL)

Finish: Painted

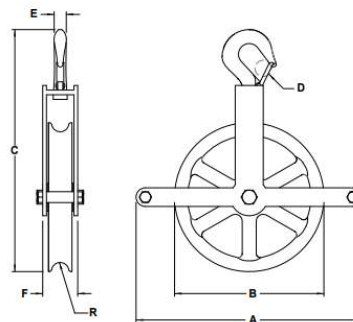

WARNING Never Exceed working load limits !

Roller Shackles

Used for lashing equipment on lumber vessels and log carriers.



Roller Shackle									
Sheave Dia (in.)	Roller Thickness	Roller Diameter			Rope Size (in.)	WLL Tons	Weight lbs/pc		Product Code
1-1/8	2"	2-7/8"			4	4	8.2		29466028

Finish Hot Dip Galvanized

WARNING Never Exceed working load limits !



FX Yarding Blocks

Fast and strong for light duty and high speed applications
 Smooth roller bearing action with grease nipple
 Pull pin to use as snatch block
 All Black to help block blend into its surroundings.



Yarding Blocks		Measurements in inches					Weight lbs/pc	Product Code
WLL Tons	Sheave Dia.	A	B	C	c-1	d-1		
1.5	3"	6.93	3.35	1.02	3.15	0.47	3	29360030
3	4"	9.25	4.76	1.34	3.39	0.63	5	29360040

Ultimate load

3 x the Working Load Limit (WLL)

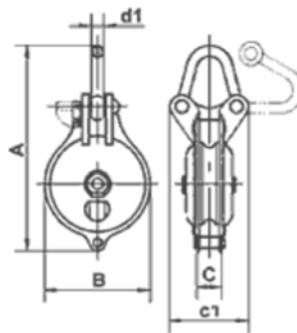

WARNING Never Exceed working load limits !

Yarding Blocks

Fast and strong for light duty and high speed applications
 Smooth roller bearing action with grease nipple
 Pull pin to use as snatch block
 Painted or H.D. Galvanized



Yarding Blocks		Measurements in inches					Weight lbs/pc	Product Code	
WLL Tons	Sheave Dia.	A	B	C	C-1	D-1		Painted	H.D. Galv
1.5	3"	6.93	3.35	1.02	3.15	0.47	3	29360300	293603001
3	4"	9.25	4.76	1.34	3.39	0.63	5	29360400	293604001
4.5	5"	12.01	5.71	1.50	4.06	0.71	9	29360500	263605001
6	6"	13.78	7.09	1.61	4.33	0.87	17	29360600	263606001
8	8"	16.73	8.86	1.81	6.50	1.10	35	29360800	263608001

Ultimate load

3 x the Working Load Limit (WLL)

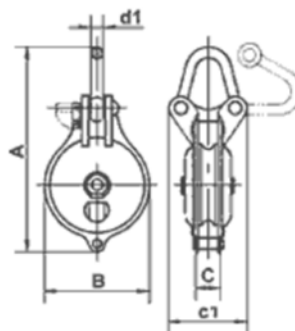

WARNING

Never Exceed working load limits !



General Warnings

All Vanguard rigging products are sold with the express understanding that both the purchaser and the end user are thoroughly familiar with the safe, proper and acceptable applications of the products.

It is the responsibility of the end user to establish proper safety programs and to provide thorough training for all personnel prior to use. The training programs must meet any federal/provincial/state/local code requirements, existing plant/site safety rules and regulations, and all instructions provided in the applicable section of this catalogue.

Product failure can occur due to abuse, misapplication, lack of maintenance, use by unqualified personnel and improper inspection prior to use. **Any failure of rigging products may result in property damage, personal injury and even death!!!!**

Standards

There are numerous government and industrial standards that cover rigging products. This catalogue makes no attempt to reference all of them; it references to the standards that are most frequently asked about.

Working Load Limit (WLL) – Safe Working Load (SWL)

The Working Load Limits shown in this catalogue are applicable to products that are new or “in as new” condition. The Working Load Limits ratings refer to the maximum amount of force or load that the rigging product can carry under normal working/environmental conditions. The Working Load Limits and Design Factor can be affected by wear, misuse, overloading, shock loading, side loading, corrosion, deformation, product alteration and other use conditions. Inspection of rigging products prior to use is required to determine whether the product continues to meet the assigned WLL provided in this catalogue, should be used at a reduced rating or removed from service.

The WLL rating must never be exceeded!!!!



General information disclaimer

The contents contained in this publication are for general information only.

Although every effort has been made to assure the accuracy of the information at time of print, persons who use the Catalog should note that ratings, laws, rules, and policies change from time to time and that these changes may alter the information contained in this publication.

Vanguard Steel Ltd. assumes no liability for Catalog errors or omissions.

It is the responsibility of each person who uses this Catalog to ascertain current information that pertains to the individual lifting program, particularly with regard to satisfactory safety compliance requirements. Check your Provincial and Local safety standards before any operation or lift is attempted.

It is the responsibility of the person/operator to frequently search for updated reference information.

Do not use lesser than matching Grade components for any lifting application !

Do not use Slings, Chains or Accessories with signs of wear or deformation !

Inspections - Each day before being used, the sling and all fastenings and attachments shall be inspected for damage or defects by a competent person designated by the employer. Additional inspections shall be performed during sling use where service conditions warrant. Damaged or defective slings shall be immediately removed from service.

Five Locations to Serve You

Toronto
Head Office
2160 Meadowpine Blvd.
Mississauga, Ontario
L5N 6H6
Phone (905) 821-1100
Fax (905) 821-2024



Montreal
2205 de l'Aviation
Dorval, Quebec
H9P 2X6
Phone (514) 685-1515
Fax (514) 685-1516



Winnipeg
190 Omands Creek Blvd.
Winnipeg, Manitoba
R2R 1V7
Phone (204) 694-2259
Fax (204) 633-7230



Edmonton
7606 McIntyre Road, N.W.
Edmonton, Alberta
T6E 6Z1
Phone (780) 466-1115
Fax (780) 469-4545



Vancouver
7880 Fraser Park Drive
Burnaby, BC
V5J 5L8
Phone (604) 294-3191
Fax (604) 294-8845

