

UNMATCHED STRENGTH

VQ - HOIST



- LIGHTER YET TOUGHER
- SEALED NEEDLE BEARING
- INTEGRATED LATCHES
- FUSED BRAKE DISC
- G100 CHAIN

VQ





VQ - LEVER HOIST RED BEAST SERIES



- All-steel construction featuring, rugged gear case and hand wheel, exceptional durability.
- Reinforce double pawl brake system and lager dia. pawl springs ensure reliable brake.
- Unique curling design-This feature enables the hand chain to successfully feed directly into the wheel sprocket from many directions and angles.
- GBO heat treated alloy load chain.
- Forged alloy Steel Hooks-Industrial rated hooks rotate 360 degrees for easy rigging. Hooks slowly stretch to indicate an overload situation increasing jobsite safety.
- Sealed roller bearings-Greatly improving performance and serve life of the product.
- Certification-Load tested to 150% of capacity with certificate.

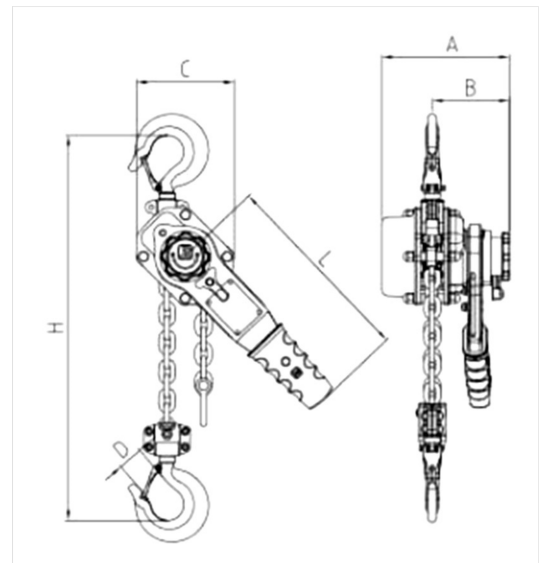
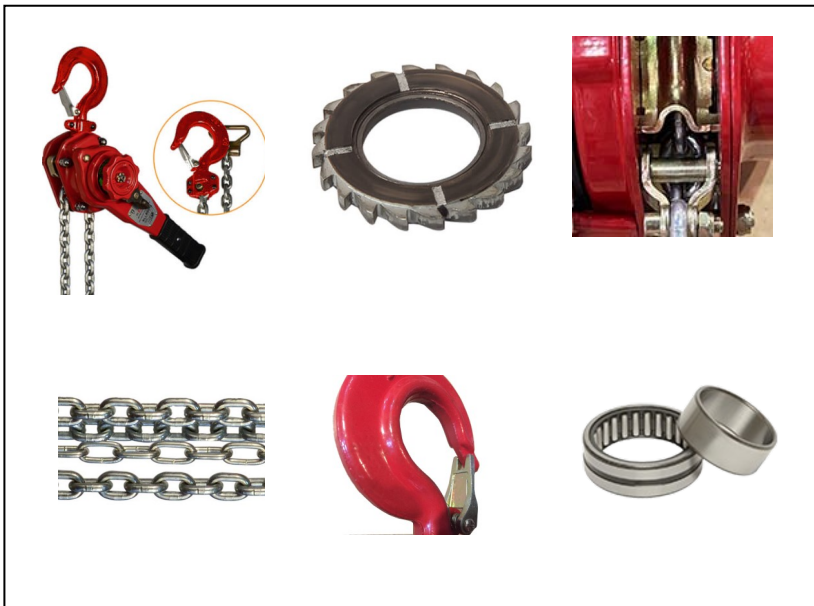

Model	VGD Part number	W.L.L.(t)	LIFT(ft)	Proof Load(t)	Lever Force kg(n)(lbs)	Load Chain		Dimensions(mm)						N.W.(kg)	Additional Weight Per Lift(kg)
						Falls	Size	H	A	B	C	D	L		
VLHK 08	385530508	0.8	5	1.2	22(215)(48)	1	5.6x15.7	300	150	100	119	24	245	6.3	0.7
VLHK 10	395530510	1	5	1.5	30(294)(66)	1	5.6x15.7	300	150	100	119	24	245	6.3	0.7
VLHK 16	395530516	1.6	5	2.4	31(304)(68)	1	7.1x19.9	350	168	104	126	32	265	8.5	1.1
VLHK 32	395530532	3.2	5	4.8	38(372)(84)	1	10x28	395	201	118	159	35	415	14.2	2.3

Custom lengths available. Call for details