

UNMATCHED STRENGTH

VQ - HOIST

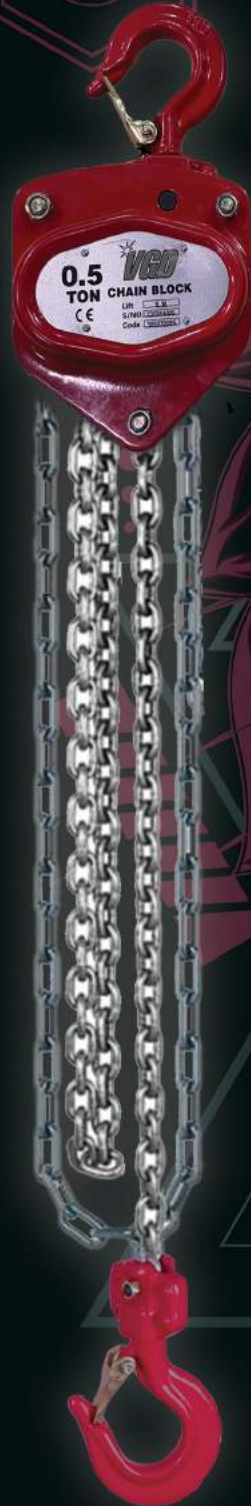

- LIGHTER YET TOUGHER
- SEALED NEEDLE BEARING
- INTEGRATED LATCHES
- FUSED BRAKE DISC
- G100 CHAIN

BRIDGES

VQ





VQ - CHAIN HOIST RED BEAST SERIES



- All-steel construction featuring, rugged gear case and hand wheel, exceptional durability.
- Reinforce double pawl brake system and lager dia. pawl springs ensure reliable brake.
- Unique curling design-This feature enables the hand chain to successfully feed directly into the wheel sprocket from many directions and angles.
- GBO heat treated alloy load chain.
- Forged alloy Steel Hooks-Industrial rated hooks rotate 360 degrees for easy rigging. Hooks slowly stretch to indicate an overload situation increasing jobsite safety.
- Sealed roller bearings - Greatly improving performance and serve life of the product.
- Certification-Load tested to 150% of capacity with certificate.

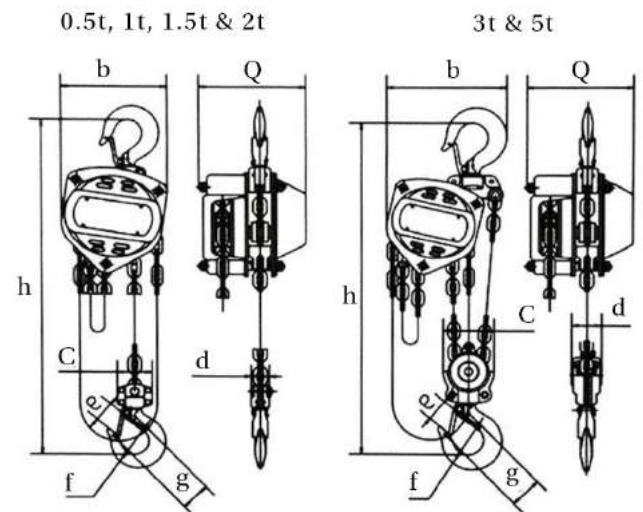
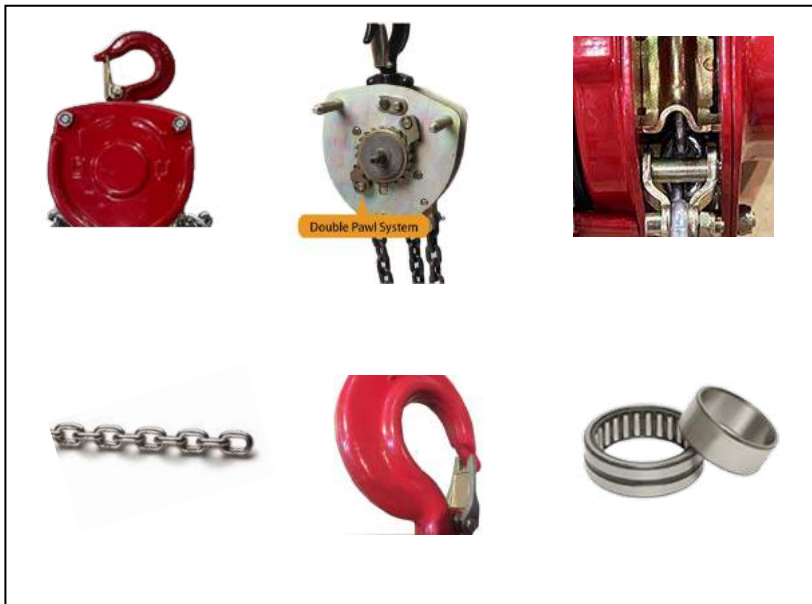

Model	VGD Part number	Rated Capacity(t)	Lift(ft)	Test Load(N)	Hand Force (N)	Load Chain		Dimensions(mm)				N.W.(kg)
						Falls	Diameter	A	b	d	h	
VQ050	395031005	0.5	10	0.75	300	1	6X18	137	137.5	35	270	8.4
VQ100	395031010	1	10	1.5	330	1	6X18	162	146.5	35.5	317	11
VQ150	395031015	1.5	10	2.25	360	1	8X24	183	170	45	399	16.2
VQ200	395031020	2	10	3	365	2	8X24	194	170	42.5	414	18.5
VQ300	395031030	3	10	4.5	385	2	8X24	220	170	50	465	25.6

Available in 10' and 20' lengths